

Self-lubrication roller chains Selbstschmierungsrollenketten

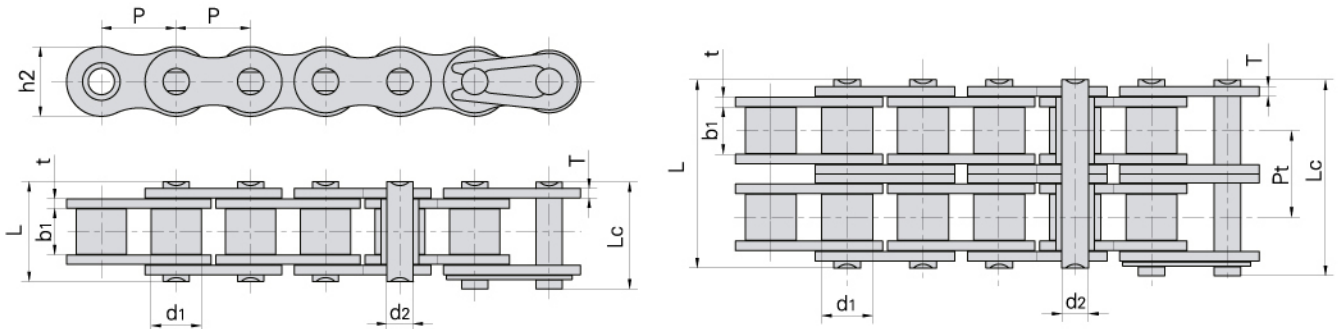

Donghua Chain No. Donghua Ketten Nr.	Pitch	Roller diameter	Width between inner plates	Pin diameter	Pin length		Inner plate depth	Plate thickness	Transverse pitch	Ultimate tensile strength	Weight per meter
	Teilung	Rollen-durchmesser	Innere Breite	Bolzen-durchmesser	Bolzen-länge		Innen-laschen-höhe	Laschen-dicke	Mitten-abstand	Min. Bruchkraft	Gewicht
	P mm	d1 max mm	b1 min mm	d2 max mm	L max mm	Lc max mm	h2 max mm	t/T max mm	Pt mm	Q min kN/LB	q kg/m
08BSLR	12.700	8.51	7.75	4.45	16.7	18.2	11.80	1.6	-	18.0/4091	0.69
08BSLRF1	12.700	8.51	7.75	4.45	17.3	18.7	11.80	1.6	-	18.0/4091	0.72
10BSLR	15.875	10.16	9.65	5.08	19.5	20.9	14.70	1.7	-	22.4/5091	0.93
10BSLRF1	15.875	10.16	9.65	5.08	19.9	21.6	14.70	1.7	-	22.4/5091	0.97
10BSLRF2	15.875	10.16	9.65	4.45	19.5	20.9	14.70	1.7	-	14.0/3181	1.20
C10BSLR	15.875	10.16	9.65	5.08	19.5	20.9	14.70	1.7	-	22.4/5089	1.06
12BSLR	19.050	12.07	11.68	5.72	22.5	24.2	16.00	1.85	-	29.0/6591	1.15
12BSLRF1	19.050	12.07	11.68	5.72	22.9	24.7	16.00	1.85	-	29.0/6591	1.19
C12BSLR	19.050	12.07	11.68	5.72	22.9	24.9	16.00	1.85	-	29.0/6589	1.32
16BSLR	25.400	15.88	17.02	8.28	36.1	37.4	21.00	4.15/3.1	-	60.0/13636	2.71
16BSLRF1	25.400	15.88	17.02	8.28	36.7	39.7	21.00	4.15/3.1	-	60.0/13636	2.73
C16BF1SLR	25.400	15.88	17.02	8.28	36.1	37.4	24.00	4.15	-	60.0/13633	3.38
C16BSLRF1	25.400	15.88	17.02	8.28	36.7	39.7	21.00	4.15	-	60.0/13633	2.98
C16BSLRF2	25.400	15.88	17.02	8.28	36.7	38.2	24.00	4.15	-	60.0/13633	3.39
40SLR	12.700	7.95	7.85	3.96	16.6	17.8	12.00	1.5	-	14.1/3205	0.62
50SLR	15.875	10.16	9.40	5.08	20.7	22.2	15.09	2.03	-	22.0/5045	1.02
60SLR	19.050	11.91	12.57	5.94	27.5	29.3	18.00	3.25/2.42	-	34.2/7772	1.65
60HSLR	19.050	11.91	12.57	5.94	29.2	31.0	18.00	3.25	-	31.8/7227	1.95
C60SLR	19.050	11.91	12.57	5.94	25.9	27.7	18.20	2.42	-	31.8/7227	1.83
80SLR	25.400	15.88	15.75	7.92	32.7	35.0	24.00	3.25	-	56.7/12886	2.60
80HSLR	25.400	15.88	15.75	7.92	36.2	38.9	24.00	4.0	-	56.7/12886	3.03
C80SLR	25.400	15.88	15.75	7.92	32.7	35.0	24.00	3.25	-	56.7/12886	3.10
100SLR	31.750	19.05	18.90	9.53	40.4	44.7	30.00	4.0	-	86.7/19699	3.94
08BSLR-2	12.700	8.51	7.75	4.45	31.2	32.2	11.80	1.6	13.92	32.0/7273	1.34
10BSLR-2	15.875	10.16	9.65	5.08	36.1	37.5	14.70	1.7	16.59	44.5/10114	1.84
12BSLR-2	19.050	12.07	11.68	5.72	42.0	43.6	16.00	1.85	19.46	57.8/13136	2.31
C12BSLR-2	19.050	12.07	11.68	5.72	42.0	43.6	16.00	1.85	19.46	57.8/13136	2.31
16BSLR-2	25.400	15.88	17.02	8.28	68.0	69.3	21.00	4.15/3.1	31.88	106.0/24091	5.42
40SLR-2	12.700	7.95	7.85	3.96	31.0	32.2	12.00	1.5	14.38	28.2/6409	1.12
50SLR-2	15.875	10.16	9.40	5.08	38.9	40.4	15.09	2.03	18.11	44.4/10091	2.00
60SLR-2	19.050	11.91	12.57	5.94	50.3	52.1	18.00	3.25/2.42	22.78	68.4/15544	3.21
80SLR-2	25.400	15.88	15.75	7.92	62.7	64.3	24.00	3.25	29.29	113.4/25773	5.15
100SLR-2	31.750	19.05	18.90	9.53	76.4	80.5	30.00	4.0	35.76	173.4/39399	7.89