

Short pitch conveyor chain with attachments

Winkellaschen-Anbauteile für Förderketten

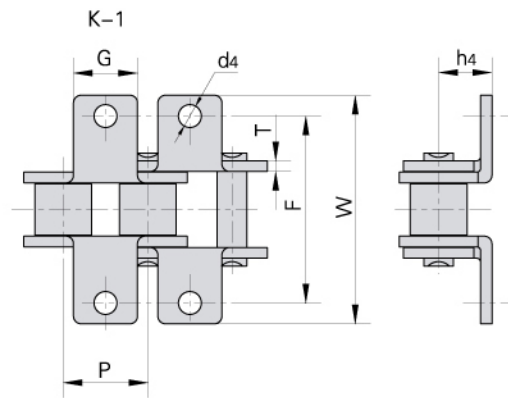
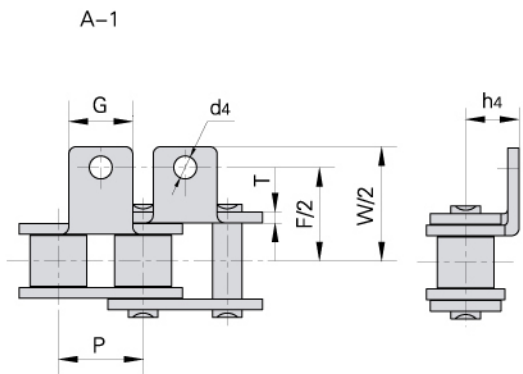

DIN/ISO Chain No.	ANSI Chain No.	P	G	F	W	T	h4	d4
<i>DIN/ISO Ketten Nr.</i>	<i>ANSI Ketten Nr.</i>	mm	mm	mm	mm	mm	mm	mm
04C	25	6.350	5.6	13.80	23.2	0.80	4.30	3.4
06C	35	9.525	7.9	19.00	28.6	1.30	6.35	3.4
08A	40	12.700	9.5	25.40	35.2	1.50	7.90	3.4
085	41	12.700	9.5	24.00	33.4	1.30	6.90	3.6
10A	50	15.875	12.7	31.75	46.2	2.03	10.30	5.5
12A	60	19.050	15.9	38.10	55.6	2.42	11.90	5.5
16A	80	25.400	19.1	50.80	64.8	3.25	15.90	6.8
20A	100	31.750	25.4	63.50	89.8	4.00	19.80	9.2
24A	120	38.100	28.6	76.20	108.5	4.80	23.00	9.8
28A	140	44.450	34.9	88.90	123.0	5.60	28.60	11.4
32A	160	50.800	38.1	101.60	142.8	6.40	31.75	13.1
40A	200	63.500	50.8	127.00	179.0	8.00	42.88	16.3
*06B		9.525	8.0	19.04	27.0	1.30	6.50	3.5
08B		12.700	9.5	25.40	36.4	1.60	8.90	4.5
10B		15.875	14.3	31.75	44.6	1.70	10.31	5.3
12B		19.050	16.0	38.10	52.4	1.85	13.46	6.4
16B		25.400	19.1	50.80	72.6	3.10	15.88	6.4
20B		31.750	35.0	63.50	100.5	3.50	19.80	9.0
24B		38.100	30.0	76.20	108.4	4.80	26.67	10.5
28B		44.450	35.0	88.90	123.0	6.00	28.58	13.1
32B		50.800	38.1	101.60	142.8	6.00	31.75	13.1

*Straight side plates
*Gerade Laschen

Short pitch conveyor chain with attachments

Planlaschen-Anbauteile für Förderketten



SA-1/M1 one side(einseitig)

SK-1/M1 both sides(beidseitig)

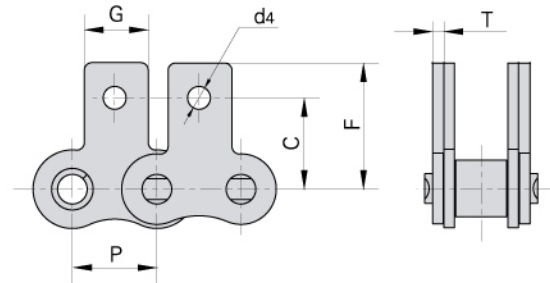
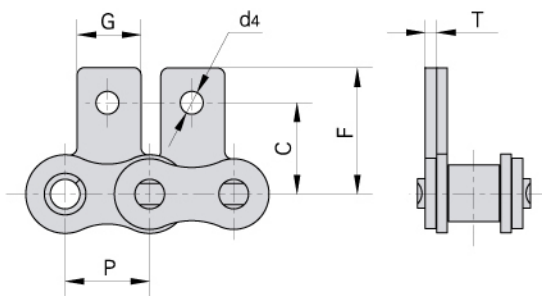

DIN/ISO Chain No. <i>DIN/ISO Ketten Nr.</i>	ANSI Chain No. <i>ANSI Ketten Nr.</i>	P	G	C	F	T	d4
		mm	mm	mm	mm	mm	mm
04C	25	6.350	5.6	7.95	11.7	0.8	3.4
06C	35	9.525	7.9	9.50	14.55	1.30	3.4
08A	40	12.700	9.5	12.70	19.05	1.50	3.4
085	41	12.700	9.5	11.85	16.55	1.30	3.6
10A	50	15.875	12.7	15.90	25.25	2.03	5.5
12A	60	19.050	15.9	18.30	29.33	2.42	5.5
16A	80	25.400	19.1	24.60	34.70	3.25	6.8
20A	100	31.750	25.4	31.80	43.30	4.00	9.2
24A	120	38.100	28.6	36.50	51.60	4.80	9.8
28A	140	44.450	34.9	44.50	62.00	5.60	11.4
32A	160	50.800	38.1	50.80	69.85	6.40	13.1
40A	200	63.500	50.8	63.50	88.90	8.00	16.3
*06B		9.525	8.0	9.52	13.50	1.30	3.5
08B		12.700	9.5	13.35	18.90	1.60	4.3
10B		15.875	14.3	16.50	22.95	1.70	5.3
12B		19.050	16.0	21.45	28.60	1.85	6.4
16B		25.400	19.1	23.15	34.00	3.10	6.4
20B		31.750	35.0	30.50	45.70	3.50	9.0
24B		38.100	36.0	36.00	61.50	4.80	10.5

*Straight side plates
*Gerade Laschen

Short pitch conveyor chain with attachments

Winkellaschen-Anbauteile für Förderketten

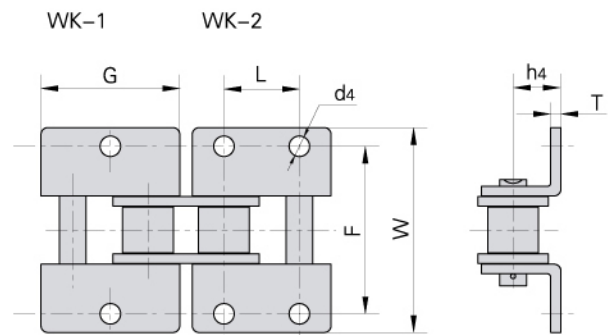
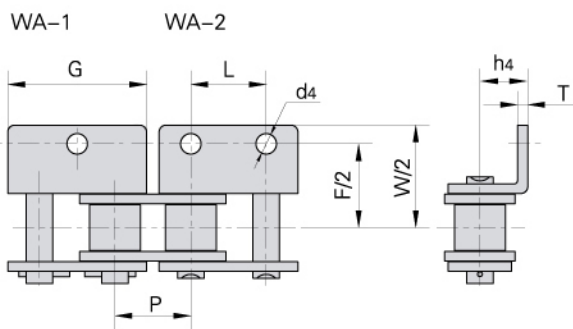

DIN/ISO Chain No.	ANSI Chain No.	P	G	L	F	W	T	h4	d4
<i>DIN/ISO Ketten Nr.</i>	<i>ANSI Ketten Nr.</i>	mm	mm	mm	mm	mm	mm	mm	mm
04C	25	6.350	11.41	6.350	13.80	23.2	0.80	4.30	3.40
06C	35	9.525	17.32	9.525	19.00	28.6	1.30	6.35	2.80
08A	40	12.700	23.00	12.700	25.40	35.6	1.50	7.90	3.40
085	41	12.700	22.30	12.700	24.00	35.0	1.30	7.20	4.85
10A	50	15.875	28.80	15.875	31.75	46.8	2.03	10.30	5.50
12A	60	19.050	34.65	19.050	38.10	56.4	2.42	11.90	5.50
16A	80	25.400	45.90	25.400	50.80	73.2	3.25	15.90	6.80
20A	100	31.750	57.65	31.750	63.50	89.8	4.00	19.80	9.20
24A	120	38.100	69.30	38.100	76.20	108.8	4.80	23.00	9.80
28A	140	44.450	80.45	44.450	88.90	123.0	5.60	28.60	11.40
32A	160	50.800	92.00	50.800	101.60	142.8	6.40	31.75	13.10
40A	200	63.500	115.50	63.500	127.00	179.0	8.00	42.88	16.30
*06B		9.525	17.72	9.525	19.04	27.0	1.30	6.50	3.50
08B		12.700	24.00	12.700	25.40	36.4	1.60	8.90	4.30
10B		15.875	29.58	15.875	31.80	44.6	1.70	10.31	5.30
12B		19.050	34.05	19.050	38.10	52.4	1.85	13.46	6.40
16B		25.400	46.40	25.400	50.80	72.6	3.10	15.88	6.40
20B		31.750	58.10	31.750	63.00	100.5	3.50	19.80	9.00
24B		38.100	71.30	38.100	76.20	108.4	4.80	26.67	10.50
28B		44.450	81.10	44.450	88.90	123.0	6.00	28.58	13.10
32B		50.800	92.80	50.800	101.60	142.8	6.00	31.75	13.10

*Straight side plates
*Gerade Laschen

Short pitch conveyor chain with attachments

Planlaschen-Anbauteile für Förderketten

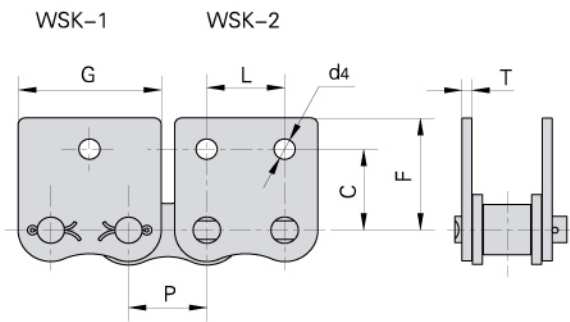
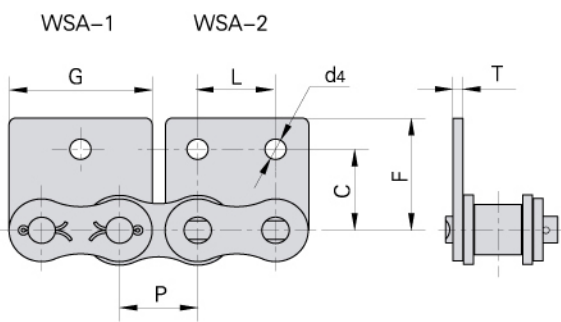

DIN/ISO Chain No. <i>DIN/ISO Ketten Nr.</i>	ANSI Chain No. <i>ANSI Ketten Nr.</i>	P	G	L	C	F	T	d4
		mm	mm	mm	mm	mm	mm	mm
04C	25	6.350	11.41	6.350	7.95	11.70	0.80	3.4
06C	35	9.525	17.32	9.525	9.50	14.55	1.30	2.8
08A	40	12.700	23.00	12.700	12.70	17.40	1.50	3.4
085	41	12.700	21.20	12.700	11.85	16.55	1.30	3.6
10A	50	15.875	28.80	15.875	15.90	23.05	2.03	5.5
12A	60	19.050	34.65	19.050	18.30	26.86	2.42	5.5
16A	80	25.400	45.90	25.400	24.60	35.45	3.25	6.8
20A	100	31.750	57.65	31.750	31.80	44.00	4.00	9.2
24A	120	38.100	69.30	38.100	36.50	51.60	4.80	9.8
28A	140	44.450	80.45	44.450	44.50	62.00	5.60	11.4
32A	160	50.800	92.00	50.800	50.80	69.85	6.40	13.1
40A	200	63.500	115.5	63.500	63.50	88.90	8.00	16.3
*06B		9.525	17.72	9.525	9.52	13.50	1.30	3.5
08B		12.700	23.30	12.700	13.35	18.90	1.60	4.3
10B		15.875	29.58	15.875	16.50	22.95	1.70	5.3
12B		19.050	34.05	19.050	21.45	28.60	1.85	6.4
16B		25.400	46.40	25.400	23.15	34.00	3.10	6.4
20B		31.750	58.10	31.750	30.50	45.70	3.50	9.0
24B		38.100	71.30	38.100	42.70	61.50	4.80	10.5

*Straight side plates
*Gerade Laschen

Short pitch conveyor chain with attachments

Winkellaschen-Anbauteile für Förderketten

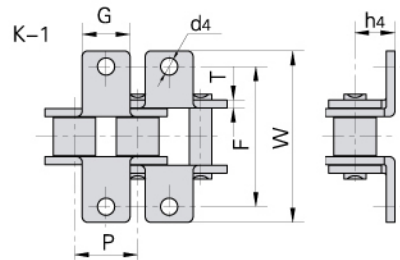
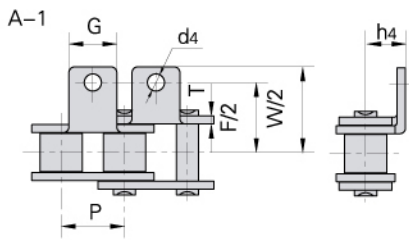

Donghua Chain No. Donghua Ketten Nr.	P	G	F	W	T	h4	d4
	mm	mm	mm	mm	mm	mm	mm
25K1F1	6.350	5.60	14.27	21.38	0.80	4.75	3.40
*06BK1F3	9.525	8.00	18.81	26.81	1.15	6.50	3.50
08AA1F1	12.700	9.50	38.50	44.50	1.50	8.20	3.60
08AA1F2	12.700	9.50	25.40	35.20	1.50	7.90	4.85
08AA1F3	12.700	15.88	25.40	35.60	1.50	8.00	4.95
08AA1F6	12.700	9.50	25.40	35.20	1.50	7.90	5.00
08AA1F7	12.700	18.00	37.00	52.00	1.50	8.00	5.20
*C08AA1F1	12.700	10.00	25.40	33.40	1.50	9.10	3.40
08BA1F2	12.700	11.40	38.60	49.60	1.60	8.90	3.50
08BA1F6	12.700	18.00	25.80	37.80	1.60	8.00	4.20
08BA1F8	12.700	11.20	21.85	32.85	2.50	8.90	4.30
08BA1F11	12.700	11.00	25.40	36.40	1.60	8.90	4.30
08BA1F16	12.700	12.30	27.80	42.80	1.60	21.00	5.20
08BA1F18	12.700	9.50	28.30	37.00	1.60	8.00	4.30
08BA1F20	12.700	12.60	22.95	33.95	1.60	10.2	5.00
08AK1F2	12.700	9.50	25.40	35.20	1.50	7.90	4.85
08AK1F4	12.700	9.50	25.39	35.19	1.50	7.90	5.50
08BK1F5	12.700	9.50	29.00	38.70	1.60	7.10	4.50
08BK1F7	12.700	9.50	29.00	39.00	1.60	7.00	4.50
08BK1F9	12.700	9.50	25.40	36.40	1.60	8.90	M4
08BK1F10	12.700	11.00	27.77	38.77	1.55	8.75	4.30
08BK1F14	12.700	11.00	25.57	36.57	1.60	8.90	6.50
08BK1F15	12.700	17.90	27.60	39.60	1.60	8.00	7.10
08BF30	12.700	18.00	27.20	40.00	1.60	8.00	4.30
08BF33	12.700	9.50	27.74	38.80	1.60	8.50	3.10
10AK1F3	15.875	14.29	31.75	46.20	2.03	10.30	5.50
10AK1F5	15.875	20.00	39.00	50.10	2.03	12.50	M5
10AK1F7	15.875	12.70	31.80	46.20	2.03	10.30	M6
10AK1F8	15.875	12.70	31.80	46.20	2.03	10.30	6.50
10AK1F9	15.875	20.00	38.97	50.07	2.03	12.50	5.50

*Straight side plates
*Gerade Laschen

Short pitch conveyor chain with attachments

Planlaschen-Anbauteile für Förderketten

Donghua Chain No. <i>Donghua Ketten Nr.</i>	P	G	F	W	T	h4	d4
	mm	mm	mm	mm	mm	mm	mm
10AHK1F1	15.875	12.70	34.00	48.40	2.42	10.30	M5
10BK1F2	15.875	13.00	32.40	45.20	1.70	11.00	6.00
12AA1F7	19.050	15.90	38.10	55.50	2.42	11.90	6.00
12AK1F1	19.050	15.90	40.00	55.60	2.42	11.90	6.20
12AK1F4	19.050	15.90	38.10	55.50	2.42	11.90	M5
12AK1F7	19.050	15.90	38.10	55.60	2.42	11.90	6.00
12AK1F8	19.050	15.90	40.00	55.60	2.42	11.90	6.80
12BA1F1	19.050	16.00	38.10	52.40	1.85	13.46	8.20
12BA1F12	19.050	18.00	35.20	52.70	1.85	12.20	6.40
12BK1F4	19.050	16.00	38.10	52.40	1.85	13.46	6.40
12BK1F5	19.050	18.00	35.44	54.05	1.80	11.60	6.40
12BK1F6	19.050	16.00	35.00	52.40	1.85	13.46	6.40
12BK1F8	19.050	18.00	35.20	50.40	1.85	12.20	6.40
12BK1F9	19.050	16.00	24.80	39.00	1.85	13.46	6.40
12BK1F10	19.050	20.50	40.00	54.50	1.85	12.00	8.50
12BK1F11	19.050	16.00	38.15	52.55	1.85	13.46	10.00
12BFK1	19.050	16.50	40.00	54.80	1.85	12.00	6.60
16AA1F4	25.400	19.10	50.80	64.80	3.25	15.90	6.00
16AK1F3	25.400	30.00	56.30	82.40	3.25	16.00	6.50
16AK1F5	25.400	25.40	44.00	56.00	3.25	15.90	6.00
16AK1F6	25.400	24.00	44.00	56.00	3.25	15.90	6.00
16BK1F3	25.400	19.10	50.80	72.60	3.10	15.88	8.20
16BK1F4	25.400	36.00	54.00	78.60	3.10	16.00	8.20
16BK1F5	25.400	25.00	57.80	83.60	3.10	19.00	9.00
16BK1F10	25.400	24.00	53.58	77.58	3.00	16.30	8.20
16BK1F11	25.400	26.00	58.00	74.60	4.00	18.00	9.00
16BK1F13	25.400	25.00	58.00	84.40	3.10	18.00	9.00
16BK1F15	25.400	25.00	68.00	130.00	3.10	17.00	9.10
16BK1F16	25.400	23.80	58.00	83.80	1.85	17.00	8.40
16BK1F17	25.400	25.00	50.80	70.20	4.15	20.20	9.10
16BK1F19	25.400	24.00	57.15	75.00	4.15	18.00	9.00
20AK1F2	31.750	25.40	53.25	77.15	6.00	19.84	8.20
20AK1F3	31.750	25.40	63.50	87.30	4.00	19.80	8.70
20AHK1F1	31.750	25.40	61.08	87.675	4.80	19.81	10.30
20BK1F2	31.750	26.00	68.00	88.00	4.50	23.50	9.60
24AA1F1	38.100	28.60	76.20	111.60	4.80	23.80	9.80

Short pitch conveyor chain with attachments

Winkellaschen-Anbauteile für Förderketten

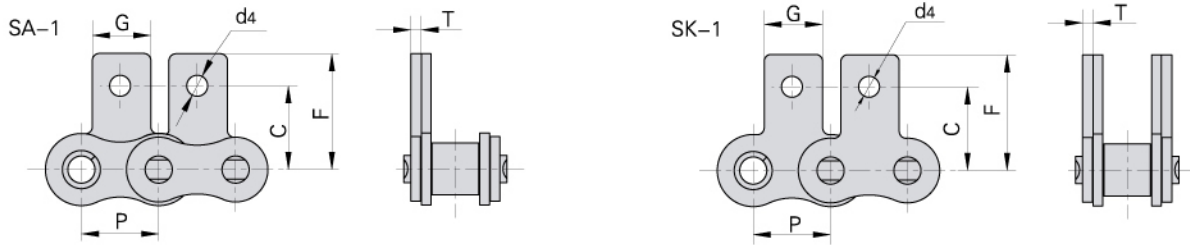

Donghua Chain No. <i>Donghua Ketten Nr.</i>	P	G	C	F	T	d4
	mm	mm	mm	mm	mm	mm
35SK1F1	9.525	7.90	9.50	14.55	1.30	4.00
*06BSK1F2	9.525	8.00	9.50	13.50	1.15	3.50
08ASA1F3	12.700	9.60	12.70	17.30	1.50	3.60
08BSA1F1	12.700	18.00	15.00	21.50	1.60	6.30
08BSA1F8	12.700	12.50	14.70	20.30	1.60	4.50
08BSA1F9	12.700	12.50	14.70	20.30	1.60	4.50
08BSK1F2	12.700	11.00	13.40	18.90	1.60	4.30
08BSK1F3	12.700	11.00	14.10	19.50	1.55	4.30
08BSK1F4	12.700	11.00	13.35	18.90	1.60	6.50
08BSK1F5	12.700	9.50	13.35	18.90	1.60	6.30
08BSK1F6	12.700	11.00	14.30	19.30	1.60	4.30
08BSK1F7	12.700	11.00	13.00	20.80	1.60	4.45
10ASA0F2	15.875	28.50	-	93.00	2.03	-
10ASK1F1	15.875	20.00	15.68	22.88	2.03	8.50
10ASK1F3	15.875	12.70	15.25	23.60	2.03	5.30
10BSA1F3	15.875	24.00	16.00	24.20	1.70	5.10
12ASA1F4	19.050	15.90	18.30	29.33	2.42	8.50
12ASK1F1	19.050	15.90	18.30	29.33	2.42	6.10
12BSK1F1	19.050	18.00	18.20	28.10	1.80	6.40
16ASAF1	25.400	19.10	-	34.70	3.25	-
16ASAF2	25.400	19.10	-	34.70	3.25	-
16BSK1F2	25.400	24.00	25.40	37.40	3.00	8.20
16BSK1F3	25.400	19.10	23.15	34.00	3.10	9.00
16AWSK1F3	25.400	45.90	16.00	34.40	3.25	14.52
24BSK1F1	38.100	30.00	42.65	61.70	4.80	10.50

*Straight side plates
*Gerade Laschen

Short pitch conveyor chain with attachments

Planlaschen-Anbauteile für Förderketten

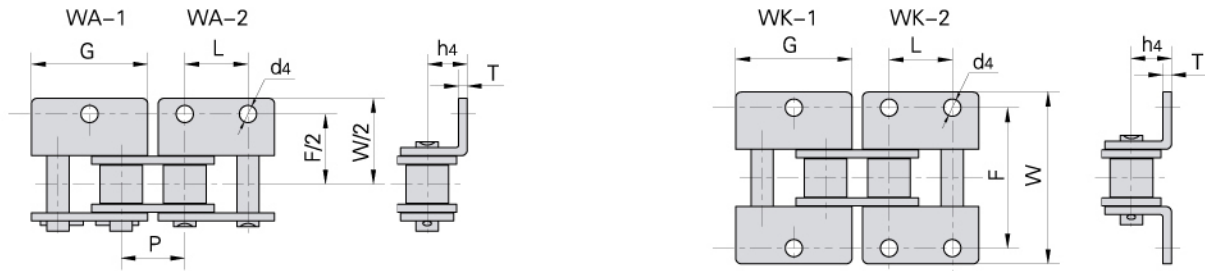

Donghua Chain No. <i>Donghua Ketten Nr.</i>	P	G	L	F	W	T	h4	d4
	mm	mm	mm	mm	mm	mm	mm	mm
*06BWK2F1	9.525	17.70	9.525	19.05	28.50	1.30	6.70	4.10
08AWA2F2	12.700	23.00	12.700	25.40	35.60	1.50	7.90	3.60
08BWA2F4	12.700	24.00	12.700	25.40	36.40	1.60	8.90	4.30
08BWA1F1	12.700	23.30	–	27.40	38.80	1.60	8.00	4.30
08BWA1F6	12.700	24.00	–	25.40	38.80	1.60	8.90	6.60
08BWA2F6	12.700	25.00	12.500	26.00	35.60	1.60	8.90	4.50
08BWK2F2	12.700	23.20	12.700	28.40	42.60	3.00	8.50	5.40
08BWK2F3	12.700	23.20	12.700	32.00	43.60	1.60	10.00	4.50
08BWK2F4	12.700	24.00	12.700	25.40	36.40	1.60	8.90	4.30
08BWK2F5	12.700	24.20	12.700	23.95	34.95	1.55	8.75	4.30
428HWK1	12.700	23.30	–	38.00	56.40	2.42	11.00	5.50
10AWK1F1	15.875	28.80	–	31.75	46.00	2.03	10.30	8.20
10AWK1F2	15.875	30.00	–	31.75	46.00	2.03	10.30	5.20
10BWA2F2	15.875	28.36	15.76	30.40	39.80	1.60	10.50	5.20
10BWK2F2	15.875	28.36	15.76	30.40	39.80	1.60	10.50	5.20
10BWK2F3	15.875	29.90	15.88	31.59	45.59	1.60	10.50	5.30
12AWA2F1	19.050	34.65	19.05	38.10	56.40	2.42	11.91	6.35
12AHWK2F1	19.050	34.65	19.05	40.60	59.00	3.25	11.90	5.50
12BWA1F2	19.050	34.05	–	38.10	26.20	1.85	13.46	5.50
12BWA2F2	19.050	34.90	19.00	35.00	50.60	1.85	12.00	6.20
12BWA2F3	19.050	30.00	20.00	37.40	53.00	1.85	12.00	6.10
12BWA2F5	19.050	30.00	20.00	39.60	55.30	1.85	14.00	M6
12BWA2F6	19.050	30.00	20.00	38.60	57.00	1.85	13.46	6.20
12BWK1F1	19.050	34.05	–	38.10	52.40	1.85	13.46	8.50
12BWK2F7	19.050	34.90	19.00	35.00	55.40	1.85	12.20	6.40

*Straight side plates
*Gerade Laschen

Short pitch conveyor chain with attachments

Winkeltaschen-Anbauteile für Förderketten

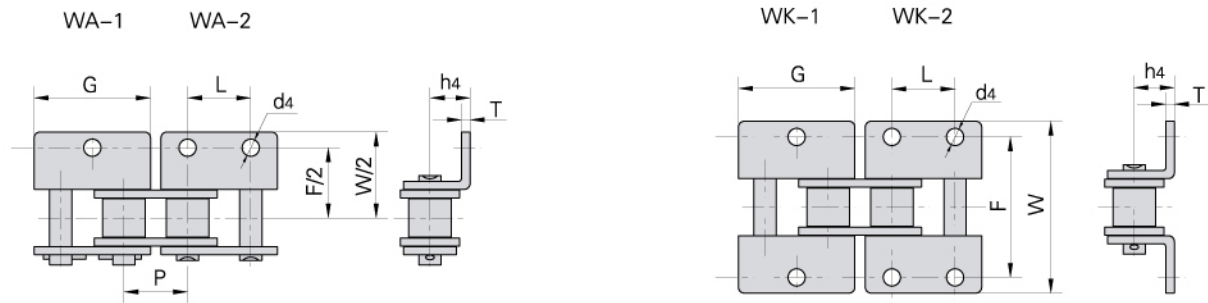

Donghua Chain No. <i>Donghua Ketten Nr.</i>	P	G	L	F	W	T	h4	d4
	mm	mm	mm	mm	mm	mm	mm	mm
12BWK2F8	19.05	35.60	19.05	38.10	52.40	1.85	13.50	6.6
12BF42WK2	19.05	34.90	19.00	35.20	54.60	1.85	12.20	6.4
16AWK1F1	25.40	45.90	-	50.80	73.20	3.25	15.90	8.0
16AWK1F2	25.40	45.90	-	50.80	73.20	3.25	15.90	12.0
16BWA2F12	25.40	46.40	25.40	50.80	77.80	3.10	15.90	8.2
16BWA2F7	25.40	46.40	25.40	50.80	72.00	4.15	16.00	8.0
16BWK1F	25.40	46.00	-	57.20	78.50	3.10	15.90	8.1
16BWK1F3	25.40	46.40	-	50.80	72.60	3.10	15.88	M6
16BWK1F4	25.40	46.40	-	50.74	72.50	3.10	15.88	8.3
16BWK2F1	25.40	48.00	25.40	58.00	75.90	3.10	18.00	9.0
16BWK2F3	25.40	46.40	25.40	58.08	72.60	3.10	15.88	8.2
16BWK2F5	25.40	46.00	25.40	53.58	77.58	3.00	16.30	8.2
16BWK2F6	25.40	49.00	25.40	50.20	72.60	4.00	19.00	8.2
16BWK2F8	25.40	46.40	25.40	50.80	79.40	4.15	15.88	6.6
16BWK2F10	25.40	46.40	25.40	52.00	72.60	3.10	15.88	6.4
16BWK2F13	25.40	47.00	25.40	58.00	75.60	4.15	18.00	9.0
20BWK2F1	31.75	58.10	31.75	67.94	100.54	3.50	19.80	9.0
28AWK2F1	44.45	82.00	42.00	69.50	99.00	5.60	25.10	10.5
32AWK2F3	50.80	100.00	70.00	100.00	140.00	6.40	31.75	18.0

Short pitch conveyor chain with attachments

Planlaschen-Anbauteile für Förderketten

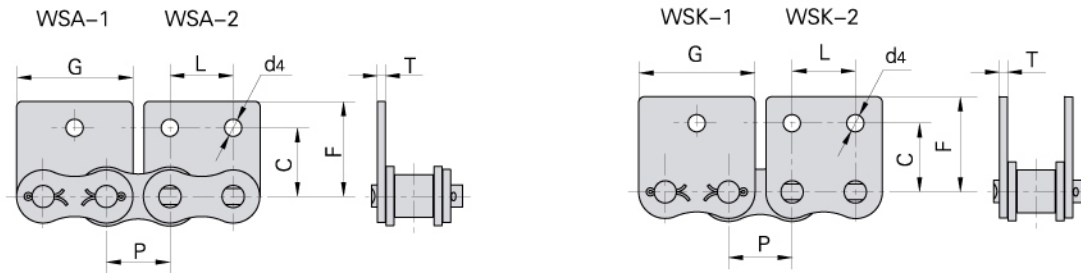

Donghua Chain No. Donghua Ketten Nr.	P	G	L	C	F	T	d4
	mm	mm	mm	mm	mm	mm	mm
*06BWSA2F1	9.525	17.60	9.50	10.10	14.50	1.30	3.30
*06BWSK2F2	9.525	17.25	9.52	9.50	13.50	1.15	3.50
08BWSA1F2	12.700	24.45	-	13.40	18.90	1.60	4.30
08BWSK2F1	12.700	23.30	12.70	13.35	18.90	1.60	6.10
08BWSK2F2	12.700	24.45	12.70	13.40	18.90	1.60	4.30
08BWSK2F3	12.700	24.20	12.70	14.10	19.50	1.55	4.30
08BWSK2F4	12.700	23.30	12.70	14.10	18.50	1.60	4.30
*C12AWSA1F1	19.050	34.05	-	17.60	25.80	2.42	9.00
12AWSK1F2	19.050	34.65	-	15.75	33.53	2.42	16.13
12BWSK1F1	19.050	35.20	-	20.58	30.30	1.85	6.35
12BWSK2F2	19.050	34.90	19.00	17.80	25.90	1.85	6.20
16AWSK1F4	25.400	45.90	-	16.00	34.40	3.25	15.56
16AWSK1F5	25.400	45.90	-	16.00	34.40	3.25	17.15
16AWSK1F6	25.400	45.90	-	16.00	34.40	3.25	16.00
16AWSK2F1	25.400	45.90	19.10	24.60	35.45	3.25	9.00
16BWSA2F6	25.400	49.00	25.40	25.50	37.60	4.00	8.20
16BWSK1F8	25.400	46.40	-	25.00	37.00	3.10	8.20
16BWSK2F5	25.400	46.00	25.40	25.40	37.50	3.00	8.20
16BWSK2F8	25.400	47.00	25.40	31.10	39.70	4.15	9.00
16BWSK2F9	25.400	47.00	25.40	31.10	39.70	4.15	9.00
16BWSK2F10	25.400	46.50	25.40	28.60	41.50	3.10	9.00
20AWSK1F1	31.750	70.00	-	45.00	70.00	4.00	50.00
20AWSK1F2	31.750	57.65	-	31.80	44.00	4.00	16.00
20AWSK1F3	31.750	57.65	-	31.80	34.98	4.00	16.00
20BWSK2F2	31.750	58.10	31.75	35.00	50.00	3.50	9.00
24BWSK2F1	38.100	71.30	38.10	45.00	55.60	4.80	10.50
32AF5	50.800	93.00	50.80	38.10	56.65	6.40	13.50

*Straight side plates

*Gerade Laschen

Short pitch conveyor chain with attachments

Winkellaschen-Anbauteile für Förderketten

FÖRDERKETTEN

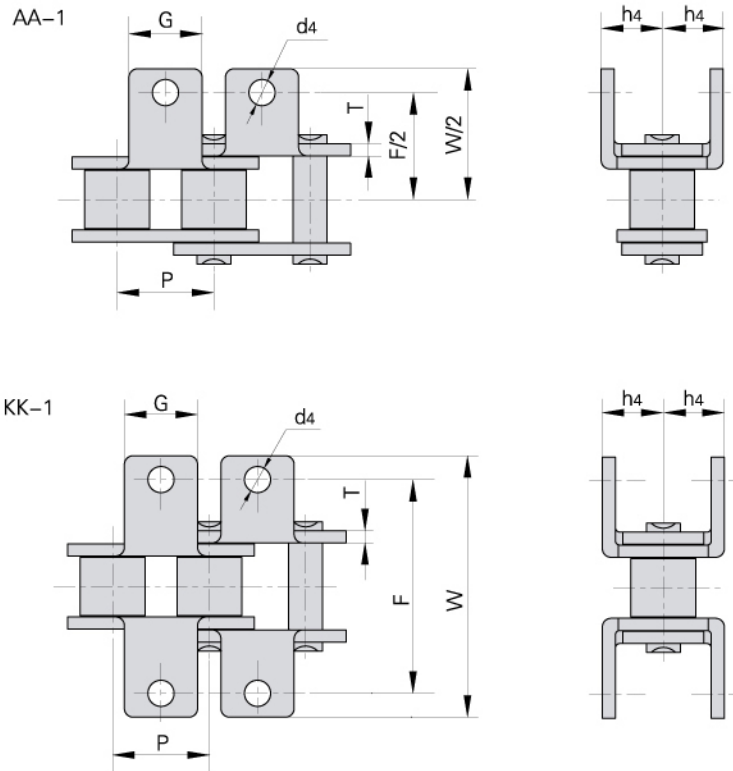

DIN/ISO Chain No. <i>DIN/ISO Ketten Nr.</i>	ANSI Chain No. <i>ANSI Ketten Nr.</i>	P	G	F	W	T	h4	d4
		mm	mm	mm	mm	mm	mm	mm
08A	40	12.700	9.5	25.40	35.2	1.50	7.90	3.4
10A	50	15.875	12.7	31.75	46.2	2.03	10.30	5.5
12A	60	19.050	15.9	38.10	55.6	2.42	11.90	5.5
16A	80	25.400	19.1	50.80	64.8	3.25	15.90	6.8
20A	100	31.750	25.4	63.50	87.3	4.00	19.80	9.2
24A	120	38.100	28.6	76.20	108.5	4.80	23.00	9.8
*06B		9.525	8.0	19.04	27.0	1.30	6.50	3.5
08B		12.700	9.5	25.40	36.4	1.60	8.90	4.5
10B		15.875	14.3	31.75	44.6	1.70	10.31	5.3
12B		19.050	16.0	38.10	52.4	1.85	13.46	6.4
16B		25.400	19.1	50.80	72.6	3.10	15.88	6.4
20B		31.750	35.0	63.50	100.5	3.50	19.80	9.0
24B		38.100	30.0	76.20	108.4	4.80	26.67	10.5

*Straight side plates
*Gerade Laschen

Short pitch conveyor chain with attachments

Planlaschen-Anbauteile für Förderketten

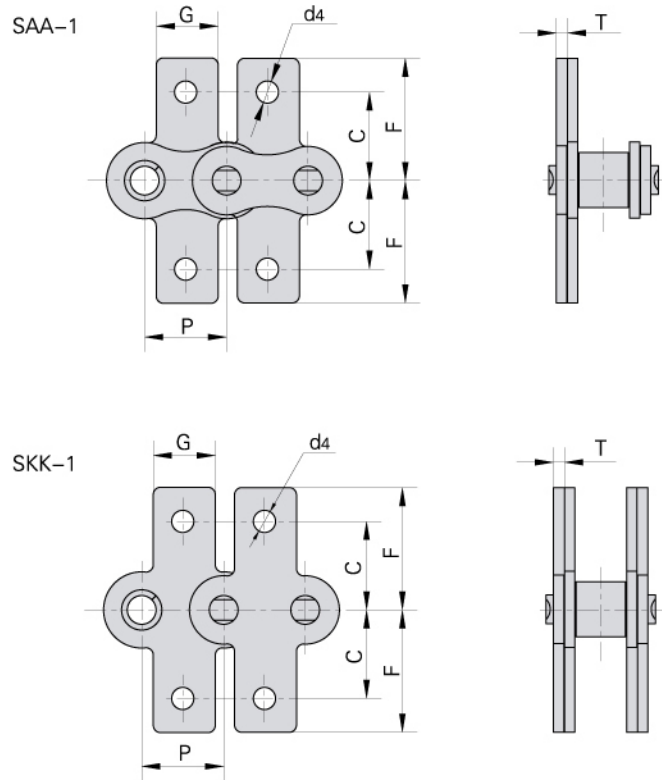

DIN/ISO Chain No. <i>DIN/ISO Ketten Nr.</i>	ANSI Chain No. <i>ANSI Ketten Nr.</i>	P	G	C	F	T	d4
		mm	mm	mm	mm	mm	mm
08A	40	12.700	9.5	12.70	19.05	1.50	3.4
10A	50	15.875	12.7	15.90	25.25	2.03	5.5
12A	60	19.050	15.9	18.30	29.33	2.42	5.5
16A	80	25.400	19.1	24.60	34.70	3.25	6.8
20A	100	31.750	25.4	31.80	43.30	4.00	9.2
24A	120	38.100	28.6	73.00	103.20	4.80	9.8
*06B		9.525	8.0	9.52	13.50	1.30	3.5
08B		12.700	9.5	13.35	18.90	1.60	4.3
10B		15.875	14.3	16.50	22.95	1.70	5.3
12B		19.050	16.0	21.45	28.60	1.85	6.4
16B		25.400	19.1	23.15	34.00	3.10	6.4
20B		31.750	35.0	30.50	45.70	3.50	9.0
24B		38.100	36.0	85.40	123.0	4.80	10.5

*Straight side plates
*Gerade Laschen