

Short pitch precision roller chains (B series)

Hochleistungsrollenkettens (B Serie)

Simplex roller chains
Einfach-Rollenketten

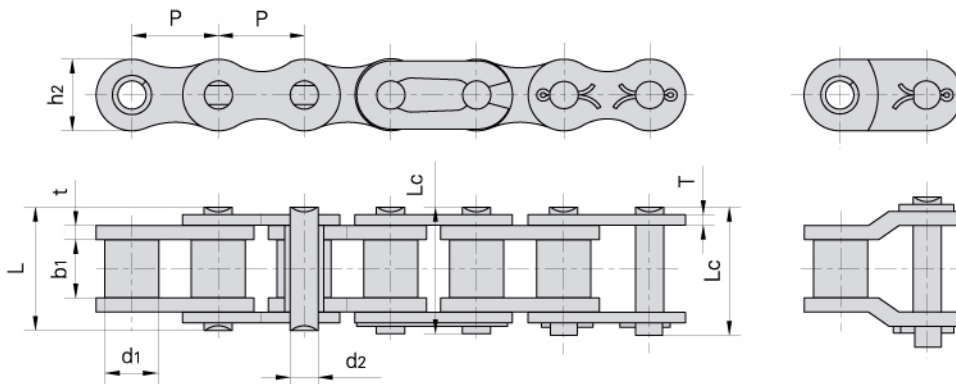

DIN/ISO Chain No. DIN/ISO Ketten Nr.	Pitch	Roller diameter	Width between inner plates	Pin diameter	Pin length		Inner plate depth	Plate thickness	Ultimate tensile strength	Average tensile strength	Weight per meter
	Teilung	Rollen-durch-messer	Innere Breite	Bolzen-durch-messer	Bolzen-länge		Innen-laschen-höhe	Laschen-dicke	Min. Bruchkraft	Durchschn. Bruchkraft	Gewicht
	P	d1 max	b1 min	d2 max	L max	Lc max	h2 max	t/T max	Q min	Q0	q
	mm	mm	mm	mm	mm	mm	mm	mm	kN/LB	kN	kg/m
04B-1	6.000	4.00	2.80	1.85	6.80	7.8	5.00	0.60	3.0/682	3.2	0.11
05B-1	8.000	5.00	3.00	2.31	8.20	8.9	7.10	0.80	5.0/1136	5.9	0.20
*06B-1	9.525	6.35	5.72	3.28	13.15	14.1	8.20	1.30	9.0/2045	10.4	0.41
08B-1	12.700	8.51	7.75	4.45	16.70	18.2	11.80	1.60	18.0/4091	19.4	0.69
10B-1	15.875	10.16	9.65	5.08	19.50	20.9	14.70	1.70	22.4/5091	27.5	0.93
12B-1	19.050	12.07	11.68	5.72	22.50	24.2	16.00	1.85	29.0/6591	32.2	1.15
16B-1	25.400	15.88	17.02	8.28	36.10	37.4	21.00	4.15/3.1	60.0/13636	72.8	2.71
20B-1	31.750	19.05	19.56	10.19	41.30	45.0	26.40	4.5/3.5	95.0/21591	106.7	3.70
24B-1	38.100	25.40	25.40	14.63	53.40	57.8	33.20	6.0/4.8	160.0/36364	178.0	7.10
28B-1	44.450	27.94	30.99	15.90	65.10	69.5	36.70	7.5/6.0	200.0/45455	222.0	8.50
32B-1	50.800	29.21	30.99	17.81	66.00	71.0	42.00	7.0/6.0	250.0/56818	277.5	10.25
40B-1	63.500	39.37	38.10	22.89	82.20	89.2	52.96	8.5/8.0	355.0/80682	394.0	16.35
48B-1	76.200	48.26	45.72	29.24	99.10	107.0	63.80	12.0/10.0	560.0/127272	621.6	25.00
56B-1	88.900	53.98	53.34	34.32	114.6	123.0	77.80	13.5/12.0	850.0/193180	940.0	35.78
64B-1	101.600	63.50	60.96	39.40	130.0	138.5	90.17	15.0/13.0	112.0/254544	1240.0	46.00
72B-1	114.300	72.39	68.58	44.48	147.4	156.4	103.60	17.0/15.0	1400.0/318180	1550.0	60.80

*Straight side plates
*Gerade Laschen

Short pitch precision roller chains (B series) Hochleistungsrollenkettens (B Serie)

Duplex roller chains
Zweifach-Rollenketten

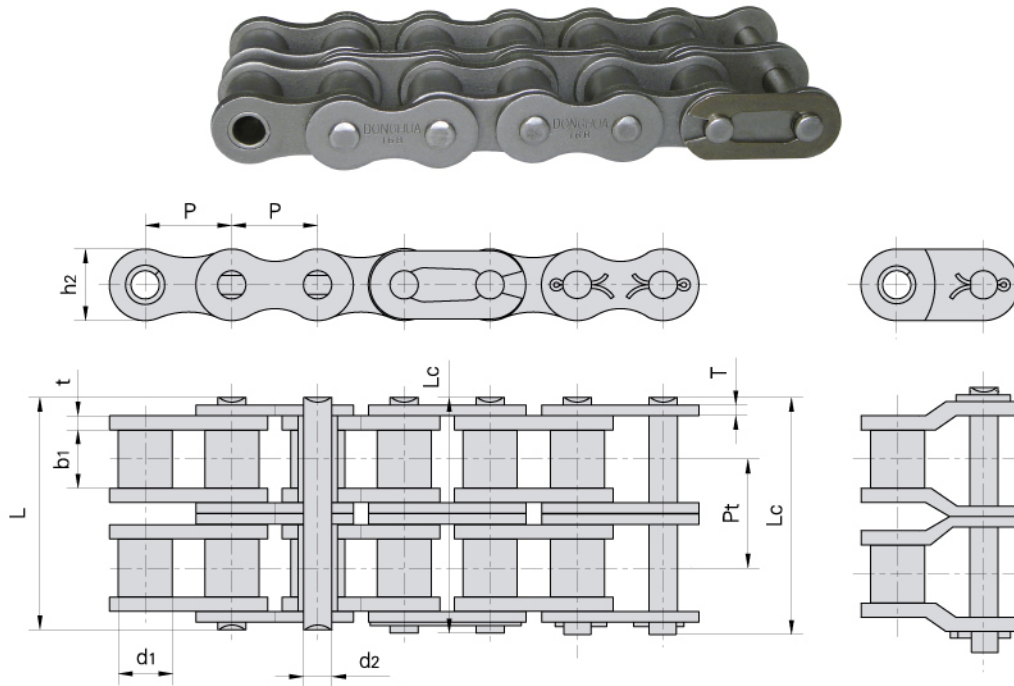

DIN/ISO Chain No.	Pitch Teilung	Roller diameter Rollen-durch-messer	Width between inner plates Innere Breite	Pin diameter Bolzen-durch-messer	Pin length Bolzen-länge	Inner plate depth Innen-laschen-höhe	Plate thickness Laschen-dicke	Transverse pitch Mitten-abstand	Ultimate tensile strength Min. Bruchkraft	Average tensile strength Durchschn. BruchKraft	Weight per meter Gewicht	
DIN/ISO Ketten Nr.	P	d ₁ max	b ₁ min	d ₂ max	L max	L _c max	h ₂ max	t/T max	P _t	Q min	Q ₀	q
	mm	mm	mm	mm	mm	mm	mm	mm	mm	KN/LB	KN	kg/m
05B-2	8.000	5.00	3.00	2.31	13.9	14.5	7.10	0.80	5.64	7.8/1773	10.2	0.33
*06B-2	9.525	6.35	5.72	3.28	23.4	24.4	8.20	1.30	10.24	16.9/3841	18.7	0.77
08B-2	12.700	8.51	7.75	4.45	31.0	32.2	11.80	1.60	13.92	32.0/7273	38.7	1.34
10B-2	15.875	10.16	9.65	5.08	36.1	37.5	14.70	1.70	16.59	44.5/10114	56.2	1.84
12B-2	19.050	12.07	11.68	5.72	42.0	43.6	16.00	1.85	19.46	57.8/13136	66.1	2.31
16B-2	25.400	15.88	17.02	8.28	68.0	69.3	21.00	4.15/3.1	31.88	106.0/24091	133.0	5.42
20B-2	31.750	19.05	19.56	10.19	77.8	81.5	26.40	4.5/3.5	36.45	170.0/38636	211.2	7.20
24B-2	38.100	25.40	25.40	14.63	101.7	106.2	33.20	6.0/4.8	48.36	280.0/63636	319.2	13.40
28B-2	44.450	27.94	30.99	15.90	124.6	129.1	36.70	7.5/6.0	59.56	360.0/81818	406.8	16.60
32B-2	50.800	29.21	30.99	17.81	124.6	129.6	42.00	7.0/6.0	58.55	450.0/102273	508.5	21.00
40B-2	63.500	39.37	38.10	22.89	154.5	161.5	52.96	8.5/8.0	72.29	630.0/143182	711.9	32.00
48B-2	76.200	48.26	45.72	29.24	190.4	198.2	63.80	12.0/10.0	91.21	1000.0/227272	1130.0	50.00
56B-2	88.900	53.98	53.34	34.32	221.2	229.6	77.80	13.5/12.0	106.60	1600.0/363635	1760.0	71.48
64B-2	101.600	63.50	60.96	39.40	249.9	258.4	90.17	15.0/13.0	119.89	2000.0/454544	2200.0	91.00
72B-2	114.300	72.39	68.58	44.48	283.7	292.7	103.60	17.0/15.0	136.27	2500.0/568180	2750.0	120.40

*Straight side plates
*Gerade Laschen

Short pitch precision roller chains (B series) Hochleistungsrollenkettens (B Serie)

Triplex roller chains
Dreifach-Rollenketten

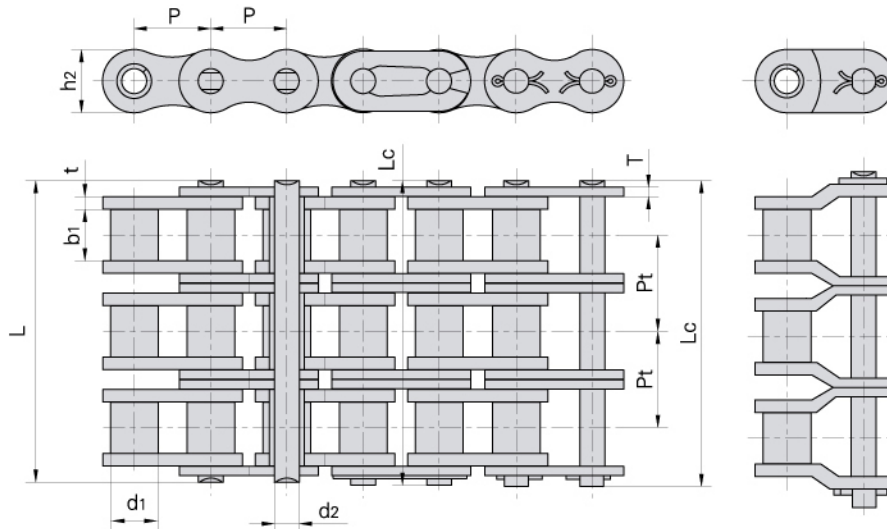

DIN/ISO Chain No.	Pitch	Roller diameter	Width between inner plates	Pin diameter	Pin length	Inner plate depth	Plate thickness	Transverse pitch	Ultimate tensile strength	Average tensile strength	Weight per meter	
<i>Teilung</i>	<i>Rollen-durchmesser</i>	<i>Innere Breite</i>	<i>Bolzen-durchmesser</i>	<i>Bolzen-länge</i>	<i>Innen-laschen-höhe</i>	<i>Laschen-dicke</i>	<i>Mitten-abstand</i>	<i>Min. Bruchkraft</i>	<i>Durchschn. BruchKraft</i>	<i>Gewicht</i>		
<i>DIN/ISO Ketten Nr.</i>	P	d1 max	b1 min	d2 max	L max	Lc max	h2 max	t/T max	Pt	Q min	Q0	q
	mm	mm	mm	mm	mm	mm	mm	mm	mm	kN/LB	kN	kg/m
05B-3	8.000	5.00	3.00	2.31	19.5	20.2	7.10	0.80	5.64	11.1/2523	13.8	0.48
*06B-3	9.525	6.35	5.72	3.28	33.5	34.6	8.20	1.30	10.24	24.9/5659	30.1	1.16
08B-3	12.700	8.51	7.75	4.45	45.1	46.1	11.80	1.60	13.92	47.5/10795	57.8	2.03
10B-3	15.875	10.16	9.65	5.08	52.7	54.1	14.70	1.70	16.59	66.7/15159	84.5	2.77
12B-3	19.050	12.07	11.68	5.72	61.5	63.1	16.00	1.85	19.46	86.7/19705	101.8	3.46
16B-3	25.400	15.88	17.02	8.28	99.8	101.2	21.00	4.15/3.1	31.88	160.0/36364	203.7	8.13
20B-3	31.750	19.05	19.56	10.19	114.2	117.9	26.40	4.5/3.5	36.45	250.0/56818	290.0	10.82
24B-3	38.100	25.40	25.40	14.63	150.1	154.6	33.20	6.0/4.8	48.36	425.0/96591	493.0	20.10
28B-3	44.450	27.94	30.99	15.90	184.2	188.7	36.70	7.5/6.0	59.56	530.0/120454	609.5	24.92
32B-3	50.800	29.21	30.99	17.81	183.2	188.2	42.00	7.0/6.0	58.55	670.0/152273	770.5	31.56
40B-3	63.500	39.37	38.10	22.89	226.8	233.8	52.96	8.5/8.0	72.29	950.0/215909	1092.5	48.10
48B-3	76.200	48.26	45.72	29.24	281.6	289.4	63.80	12.0/10.0	91.21	1500.0/340909	1710.0	75.00
56B-3	88.900	53.98	53.34	34.32	327.8	336.2	77.80	13.5/12.0	106.6	2240.0/545450	2240.0	107.18
64B-3	101.60	63.50	60.96	39.40	369.8	378.3	90.17	15.0/13.0	119.89	3000.0/681820	3300.0	136.00
72B-3	114.30	72.39	68.58	44.48	420.0	429.0	103.60	17.0/15.0	136.27	3750.0/852270	4125.0	180.00

*Straight side plates
*Gerade Laschen