

Roller chains for folio transport (Gripper)

Rollenketten für den Folientransport

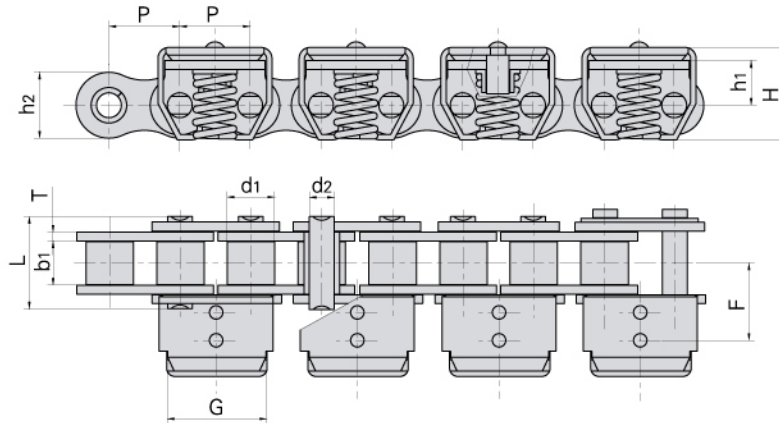

Donghua Chain No. Donghua Ketten Nr.	Pitch	Roller diameter	Width between inner plates	Pin diameter	Pin length	Attachment dimension					Ultimate tensile strength	Weight per meter
	Teilung	Rollen-durchmesser	Innere Breite	Bolzen-durchmesser	Bolzen-länge	Befestigungs-laschen-abmessungen					Min. Bruchkraft	Gewicht
	P	d1 max	b1 min	d2 max	L max	h2 max	F	h1	H	T	Q min	q
	mm	mm	mm	mm	mm	mm	mm	mm	mm	mm	kN/LB	kg/m
08BSSF32	12.7	8.51	7.75	4.45	16.7	11.8	13.8	8.0	16.5	1.6	12.0/2727	1.14

Support chains

Rollenketten für die Papierindustrie

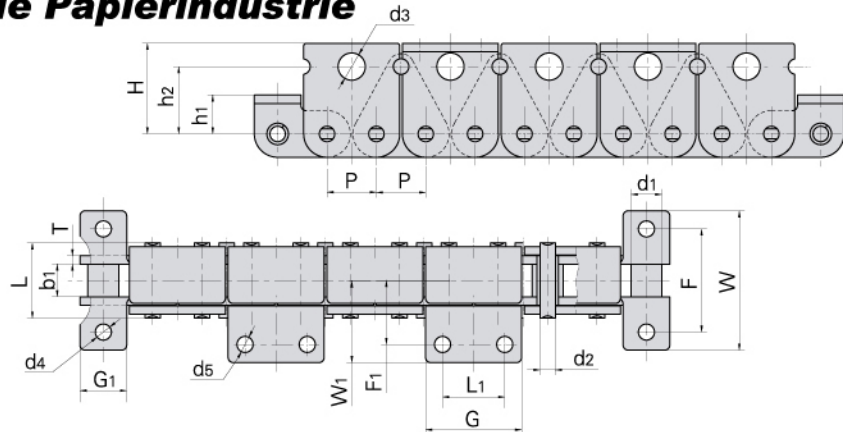

Donghua Chain No. Donghua Ketten Nr.	Pitch	Roller diameter	Width between inner plates	Pin diameter	Pin length	Ultimate tensile strength	Weight per meter
	Teilung	Rollen-durchmesser	Innere Breite	Bolzen-durchmesser	Bolzen-länge	Min. Bruchkraft	Gewicht
	P	d1 max	b1 min	d2 max	L max	Q min	q
	mm	mm	mm	mm	mm	KN/LB	kg/m
12AH-TB35	19.05	11.91	12.57	5.94	29.2	31.8/7227	4.35

Donghua Chain No. Donghua Ketten Nr.	H	h2	d3	F	W	G1	h1	d4	T	F1	W1	L1	G	d5
	mm	mm	mm	mm	mm	mm	mm	mm	mm	mm	mm	mm	mm	mm
12AH-TB35	35.0	26.0	10.5	40.0	54.0	18.0	15.0	6.2	3.25	24.8	31.8	24.0	37.0	6.2