

## To top chain - curved movement Plattenbandketten

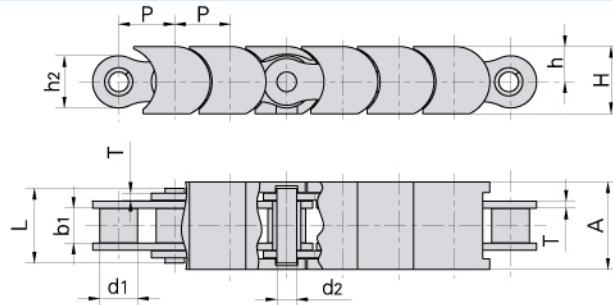

Donghua Chain No. Donghua Ketten Nr.	Pitch	Roller diameter	Width between inner plates	Pin diameter	Pin length	Plate dimension		Plastic attachment dimension			Ultimate tensile strength
	Teilung	Rollen-durchmesser	Innere Breite	Bolzen-durchmesser	Bolzen-länge	Laschen-abmessungen		Plastik-befestigungs-laschen-abmessungen			Min. Bruchkraft
	P	d1 max	b1 min	d2 max	L max	h2 max	T max	A	h	H	Q min
	mm	mm	mm	mm	mm	mm	mm	mm	mm	mm	kN/LB
08B-TP	12.700	8.51	7.75	4.45	16.7	11.8	1.60	19.8	8.0	15.2	18/4091
10B-TP	15.875	10.16	9.65	5.08	19.5	14.7	1.70	24.8	9.5	17.5	22.4/5091
12B-TP	19.050	12.07	11.68	5.72	22.5	16.0	1.85	29.8	11.0	19.8	29/6591

## Double flex chains Double flex Ketten

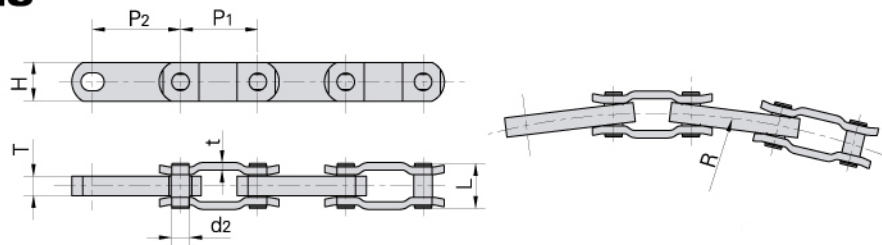

Donghua Chain No. Donghua Ketten Nr.	Pitch	Pitch	Thickness of inner plates	Pin diameter	Pin length	Plate dimension		Side bow radius	Ultimate tensile strength	Average tensile strength	Weight per meter
	Teilung	Teilung	Innen-laschen-dicke	Bolzen-durchmesser	Bolzen-länge	Laschen-abmessungen		Seiten-bogen-radius	Min. Bruchkraft	Durchschn. Bruchkraft	Gewicht
	P1	P2	T	d2 max	L max	H max	t	R min	Q min	Q0	q
	mm	mm	mm	mm	mm	mm	mm	mm	kN/LB	kN	kg/m
3500	63.5	76.2	15.9	14.27	37.0	32.0	6.3	508.0	160.0/36363	196.0	5.14

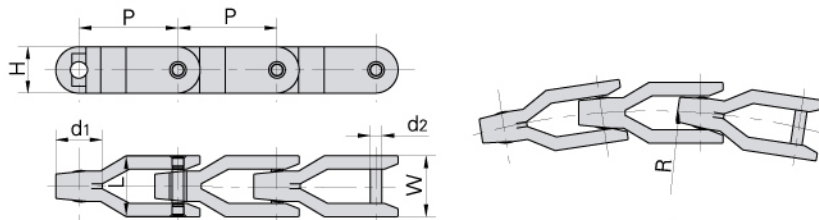

Donghua Chain No. Donghua Ketten Nr.	Pitch	Pin diameter	Pin length	Plate dimension			Side bow radius	Ultimate tensile strength	Weight per meter
	Teilung	Bolzen-durchmesser	Bolzen-länge	Laschen-abmessungen			Seitenbogen-radius	Min. Bruchkraft	Gewicht
	P	d2 max	L	H max	W max	d1	R min	Q min	q
	mm	mm	mm	mm	mm	mm	mm	kN/LB	kg/m
CC1400	81.3	9.5	48.0	38.5	50.0	38.0	500	30.0/6818	1.99