

SCRAPER CONVEYOR CHAINS
KRATZER-FÖRDERKETTEN

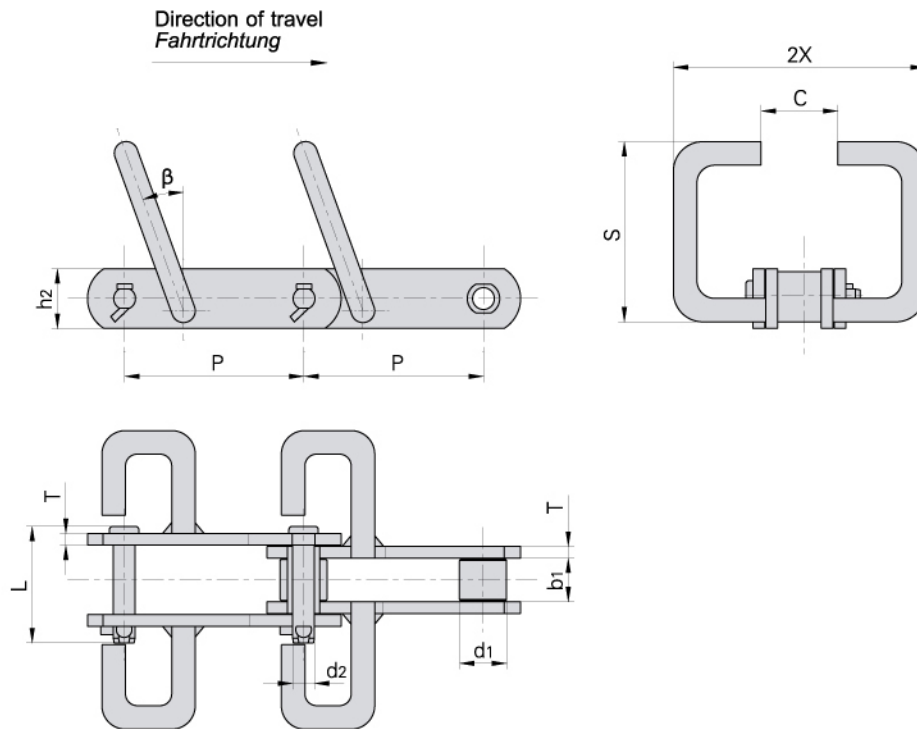

Scraper conveyor chains

Kratzer-Förderketten



Donghua Chain No. Donghua Ketten Nr.	Pitch	Roller diameter	Width between inner plates	Pin diameter	Pin length	Plate depth	Plate thickness	Attachment dimension			Ultimate tensile strength	Weight per meter	
	Teilung	Rollen-durchmesser	Innere Breite	Bolzen-durchmesser	Bolzen-länge	Laschen-höhe	Laschen-dicke	Befestigungs-laschen-abmessungen			Min. Bruchkraft	Gewicht	
	P	d1 max	b1	d2	L	h2	T	S	2X	C	β	Q	q
	mm	mm	mm	mm	mm	mm	mm	mm	mm	mm	°	kN/LB	kg/m
P152F51	152.4	40	36	18.5	95.5	50.8	10	175	310	110	20°	170/38242	24.9

Scraper conveyor chains

Kratzer-Förderketten

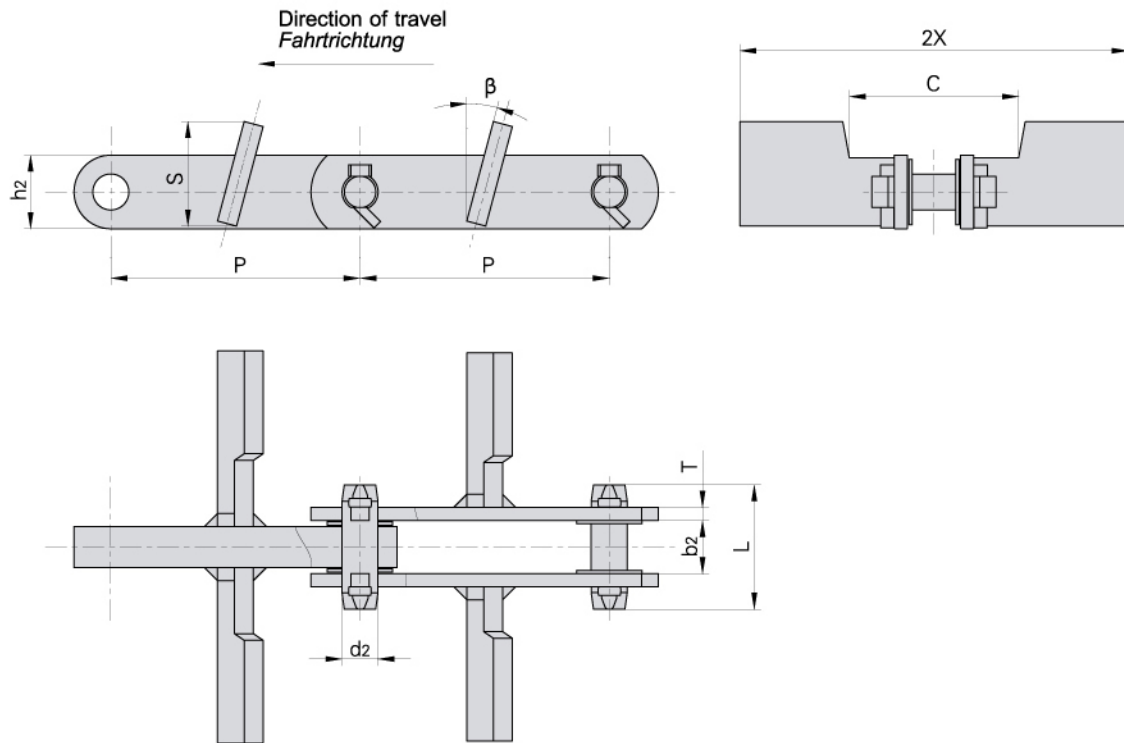

Donghua Chain No. Donghua Ketten Nr.	Pitch	Width between outer plates	Pin diameter	Pin length	Plate depth	Plate thickness	Attachment dimension			Ultimate tensile strength	Weight per meter	
	Teilung	Breite zwischen den Außenlaschen	Bolzen-durchmesser	Bolzen-länge	Laschen-höhe	Laschen-dicke	Befestigungs-laschen-abmessungen			Min. Bruchkraft	Gewicht	
	P	b2	d2	L	h2	T	S	2X	C	β	Q	q
	mm	mm	mm	mm	mm	mm	mm	mm	mm		kN/LB	kg/m
P152F45	152.4	32.5	22.0	76.0	45.0	81	64.0	326	104	15°	260/58489	20.40
P152F45A	152.4	32.5	22.0	76.0	45.0	81	83.0	286	106	15°	260/58489	20.80
P152F45B	152.4	32.5	22.0	76.0	45.0	81	64.0	276	106	15°	260/58489	18.00
P152F45C	152.4	32.5	22.0	76.0	45.0	81	64.0	227	106	15°	260/58489	16.50
P152F47	152.4	34.0	22.0	85.0	45.0	12	81.0	400	106	15°	400/89983	30.90
P150F17A	150.0	25.0	18.5	66.3	38.1	10	115.0	180	90	15°	150/33743	14.50
P200F29	200.0	40.5	35.0	104.0	80.0	13	168.0	420	112	15°	530/119227	50.60
P200F29A	200.0	40.5	35.0	104.0	80.0	13	148.0	430	112	15°	530/119227	53.90
P200F35	200.0	33.0	26.5	79.0	50.0	10	145.5	430	210	15°	400/89983	28.93

Scraper conveyor chains

Kratzer-Förderketten

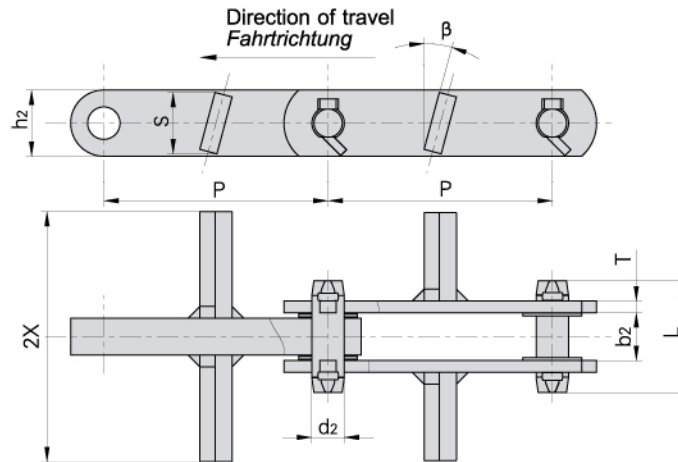

Donghua Chain No. Donghua Ketten Nr.	Pitch	Width between outer plates	Pin diameter	Pin length	Plate depth	Plate thickness	Attachment dimension			Ultimate tensile strength	Weight per meter
	Teilung	Breite zwischen den Außenlaschen	Bolzen-durchmesser	Bolzen-länge	Laschen-höhe	Laschen-dicke	Befestigungs-laschen-abmessungen			Min. Bruchkraft	Gewicht
	P	b2	d2	L	h2	T	S	2X	β	Q	q
	mm	mm	mm	mm	mm	mm	mm	mm		kN/LB	kg/m
P101.6F20	101.6	16.5	17.46	53.7	38.0	6	34	210	45°	100/22496	7.26
P152F2	152.4	33.3	22.00	76.5	45.0	8	38	180	20°	260/58489	12.1
P152F45D	152.4	32.5	22.00	76.0	45.0	8	42	170	15°	260/58489	13.5
P152F45E	152.4	32.5	22.00	76.0	45.0	8	42	280	15°	260/58489	16.2
P152F45F	152.4	32.5	22.00	76.0	45.0	8	42	227	15°	260/58489	14.9
P152F46	152.4	40.8	25.00	86.0	50.0	9	49	290	15°	300/67487	20.8
P150F17B	150.0	25.0	18.50	67.3	38.1	10	36	178	15°	150/33743	10.6

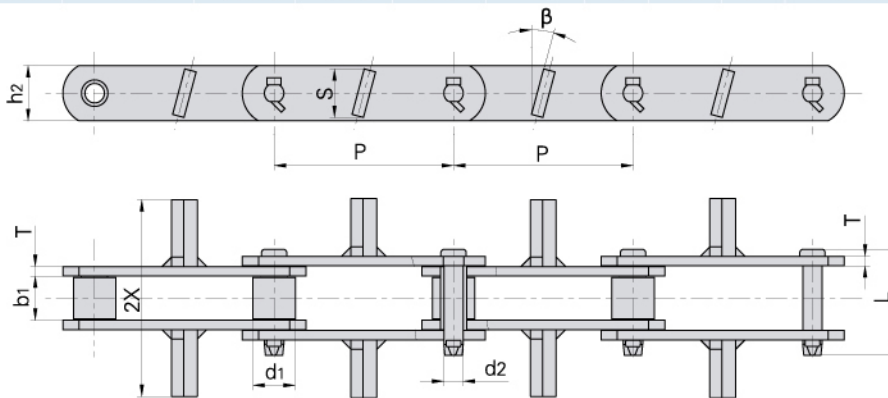

Donghua Chain No. Donghua Ketten Nr.	Pitch	Width between inner plates	Roller diameter	Pin diameter	Pin length	Plate depth	Plate thickness	Attachment dimension			Ultimate tensile strength	Weight per meter
	Teilung	Innere Breite	Rollen-durchmesser	Bolzen-durchmesser	Bolzen-länge	Laschen-höhe	Laschen-dicke	Befestigungs-laschen-abmessungen			Min. Bruchkraft	Gewicht
	P	b1	d1	d2	L	h2	T	S	2X	β	Q	q
	mm	mm	mm	mm	mm	mm	mm	mm	mm		kN/LB	kg/m
P152F48	152.4	37.6	36.0	16.5	90	47	8	42	170	15°	180/40492	12.1
RO6205MF3	152.4	37.0	38.1	15.9	88	45	8	42	170	15°	170/38242	12.4

Scraper conveyor chains

Kratzer-Förderketten

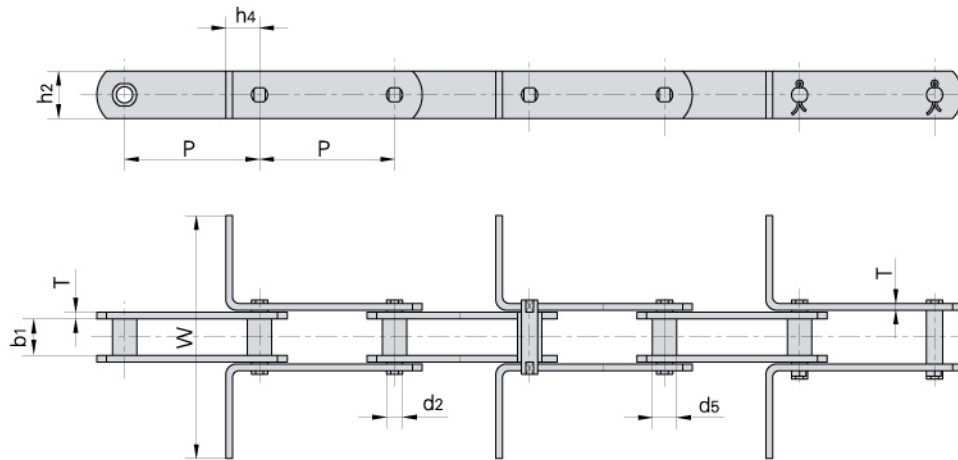

Donghua Chain No. Donghua Ketten Nr.	P	b1 min	d2 max	d5 max	h4	h2 max	T max	W	Q min
	mm	mm	mm	mm	mm	mm	mm	mm	kN/LB
MR56	100 125 -	24.0	10.0	15.0	20.0	30.0	4.0	•	56.0/12727
MR80	100 125 160	28.0	12.0	18.0	25.0	35.0	5.0	•	80.0/18182
MR112	100 125 160	32.0	15.0	21.0	35.0	40.0	6.0	•	112.0/25454
MR160	100 125 160	37.0	18.0	25.0	40.0	50.0	7.0	•	160.0/36364
MR224	125 160 200	43.0	21.0	30.0	44.0	60.0	8.0	•	224.0/50909
MR315	160 200 250	48.0	25.0	36.0	50.0	70.0	10.0	•	315.0/71591

Donghua Chain No. Donghua Ketten Nr.	P	b1 min	d2 max	d5 max	h4	h2 max	T max	W	Q min
	mm	mm	mm	mm	mm	mm	mm	mm	kN/LB
FVR40	80 100 125	18.0	10.0	15.0	20.0	25.0	3.0	•	42.0/9545
FVR63	100 125 160	22.0	12.0	18.0	25.0	30.0	4.0	•	64.0/14545
FVR90	100 125 160	25.0	14.0	20.0	30.0	35.0	5.0	•	100.0/22727
FVR112	100 125 160	30.0	16.0	22.0	35.0	40.0	6.0	•	120.0/27272
FVR140	125 160 200	35.0	18.0	26.0	38.0	45.0	6.0	•	145.0/32954
FVR180	125 160 200	45.0	20.0	30.0	44.0	50.0	8.0	•	190.0/43181
FVR250	160 200 250	55.0	26.0	36.0	50.0	60.0	8.0	•	275.0/62499

• dimensions upon the request of customers.
• Die Abmessungen sind nach Kundenwunsch festzulegen.

Scraper conveyor chains

Kratzer-Förderketten

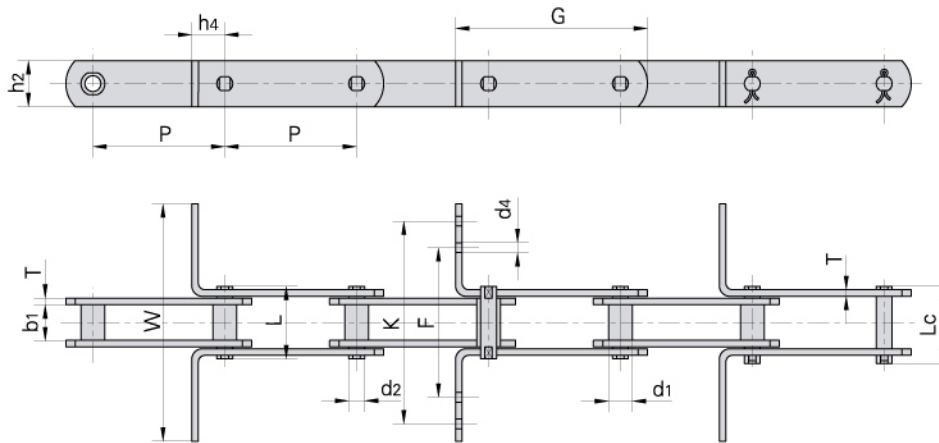

Donghua Chain No. Donghua Ketten Nr.	Pitch	Bush diameter	Width between inner plates	Pin diameter	Pin length		Ultimate tensile strength	Average tensile strength	Weight per meter
	Teilung	Buchsen-durchmesser	Innere Breite	Bolzen-durchmesser	Bolzen-länge		Min. Bruchkraft	Durchschn. Bruchkraft	Gewicht
	P	d1 max	b1 min	d2 max	L max	Lc max	Q min	Q0	q
	mm	mm	mm	mm	mm	mm	kN/LB	kN	kg/m
M80-P100F1	100.0	18.0	28.00	12.00	55.0	58.5	80.0/18162	88.0	5.19
M180-P-100	100.0	26.0	28.85	18.00	62.5	-	180.0/40909	198.0	10.25
M310-P-125	125.0	40.0*	52.00	20.00	103.4	109.4	303.8/69045	334.0	19.88
M310F1-P-125	125.0	40.0*	52.00	20.00	103.4	109.4	303.8/69045	334.0	24.88
M310F1-P-150	150.0	40.0*	52.00	20.00	103.4	109.4	303.8/69045	334.0	19.13
FVR90F1-B-125	125.0	20.0	25.00	14.00	52.0	56.4	150.0/33743	165.0	6.16
P100F16	100.0	23.0	28.00	16.00	66.0	-	115.0/26136	127.0	6.60
P101.6	101.6	44.5	50.80	23.84	136.5	-	600.0/136362	660.0	34.96
P125F3	125.0	25.0	36.00	18.00	82.0	-	220.0/49999	242.0	11.17
P125F4	125.0	25.0	36.00	18.00	82.0	-	220.0/49999	242.0	9.83
P160F12	160.0	50.0*	34.00	20.00	77.8	-	160.0/35993	176.0	10.30

Donghua Chain No. Donghua Ketten Nr.	G	F	W	K	h4	h2	d4	T
	mm	mm	mm	mm	mm	mm	mm	mm
M80-P100F1	145.5	-	180.0	-	25.0	35.0	-	5.0
M180-P-100	163.0	-	185.0	-	35.0	50.0	-	6.0
M310-P-125	195.0	-	270.0	-	35.0	55.0	-	10.0
M310F1-P-125	195.0	-	560.0	-	35.0	55.0	-	10.0
M310F1-P-150	220.0	-	350.0	-	40.0	50.0	-	10.0
FVR90F1-B-125	175.0	90.0	290.0	270.0	30.0	40.0	9.0	5.0
P100F16	143.0	91.8	180.0	159.8	25.0	36.0	6.5	6.0
P101.6	198.6	-	206.5	-	62.0	60.0	-	14.5
P125F3	190.0	139.5	290.0	259.5	35.0	51.0	8.5	6.0
P125F4	190.0	119.5	220.0	191.5	35.0	51.0	8.5	6.0
P160F12	230.0	-	214.5	-	40.0	50.0	-	6.0

* Indicate the external diameter of roller
* Außendurchmesser der Rollen